

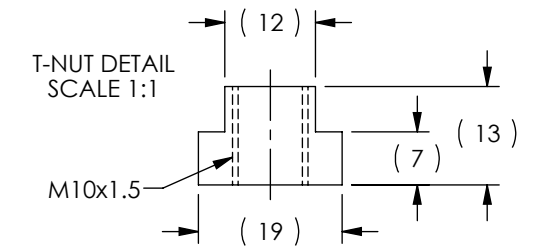

3 DIMENSIONAL VIEW
SCALE 1 : 8

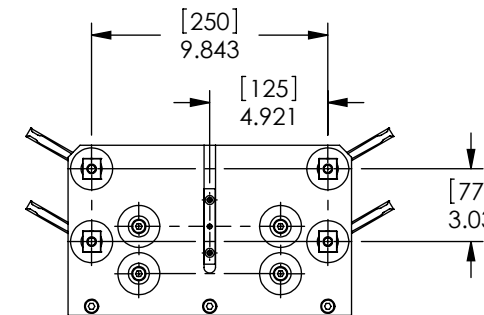
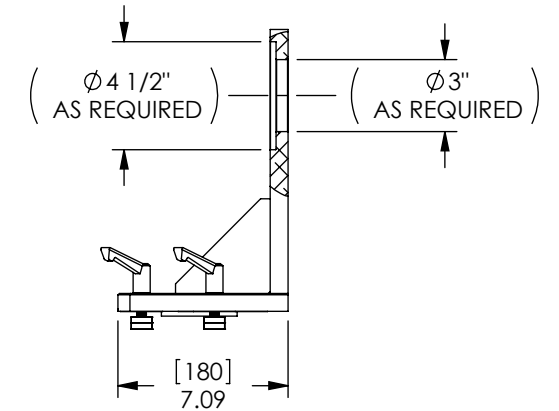
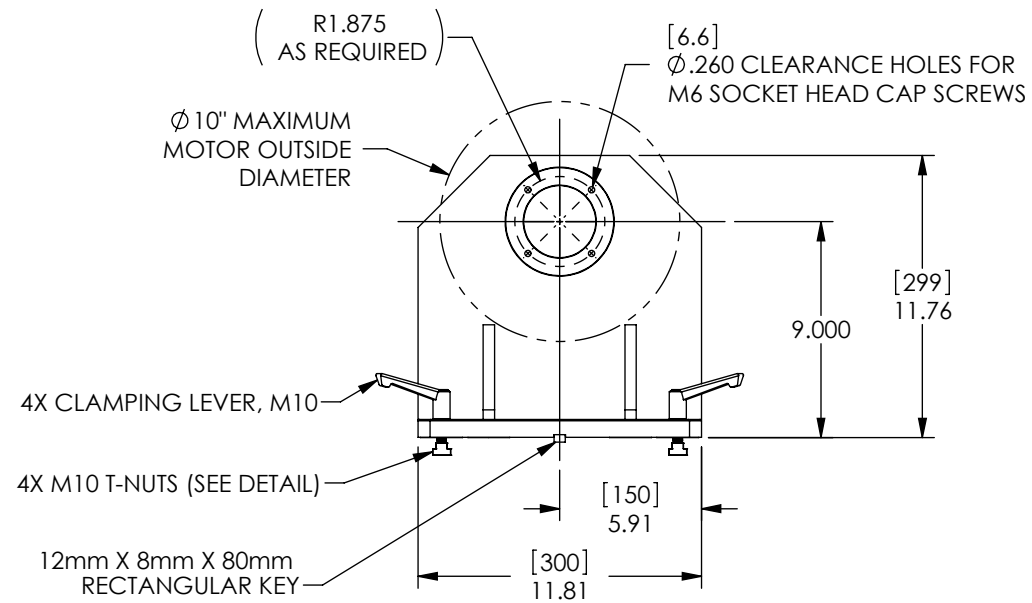
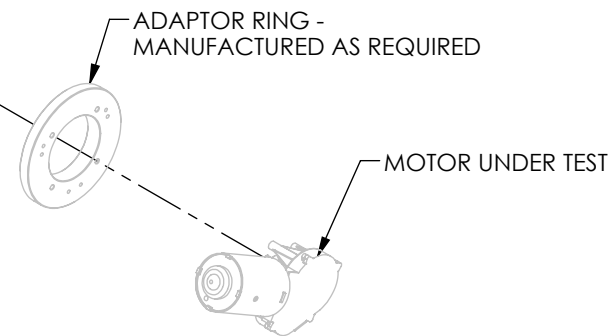

MATERIAL: -	DESIGN	AJC	07/10/08		MAGTROL INC. 70 GARDENVILLE PKWY, W. BUFFALO, NEW YORK 14224-1322	
	DRAWN	AJC	07/10/08			
FINISH: -	CHECKED	-	-	TITLE FIXED MOTOR FIXTURE, 800 SERIES, 006356		
THIRD ANGLE PROJECTION	UNLESS OTHERWISE SPECIFIED: DIMENSIONS ARE IN INCHES. DIAMETERS CONCENTRIC: .003 TIR, FACES PERPENDICULAR: .003 INTERPRETATION PER ASME Y14.5M-1994 REMOVE ALL BURRS AND BREAK SHARP EDGES .005/.010 X 45°. ALL INSIDE CORNERS TO BE .02 R MAX. TOLERANCES: .XX ± .01 FRAC. ± 1/64" .XXX ± .005 ANG. ± 1° SURFACE FINISH 125 RMS MAX. U.O.S.			USED ON: - SIMILAR TO: T11407	REV -	
THIS DRAWING AND SPECIFICATION CONTAINS PROPRIETARY INFORMATION TO MAGTROL INC. ANY DISCLOSURE OR REPRODUCTION OF THIS DOCUMENT WITHOUT WRITTEN AUTHORIZATION FROM MAGTROL INC. IS EXPRESSLY PROHIBITED	DWG. NO.			FMF-800		
	SIZE B	SCALE 1:8	SHEET # 2 OF 2			