

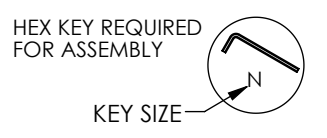

SOLID MODEL AVAILABLE

ITEM NO.	PART NUMBER	DESCRIPTION	QTY.
1	205453	RISER BLOCK, RTM-1-080	1
2	504215	T-NUT, M6x1.0 X 8mm SLOT WIDTH	4
3	504253	SHCS M5x0.8 X 20mm 18-8 SS	4
4	505677	SHCS M6x1 X 20mm 18-8 SS	4

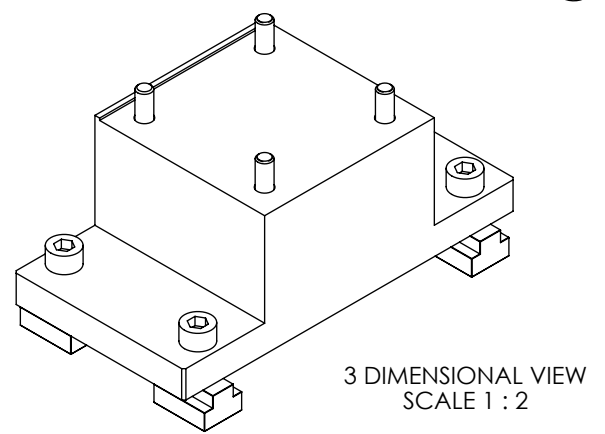
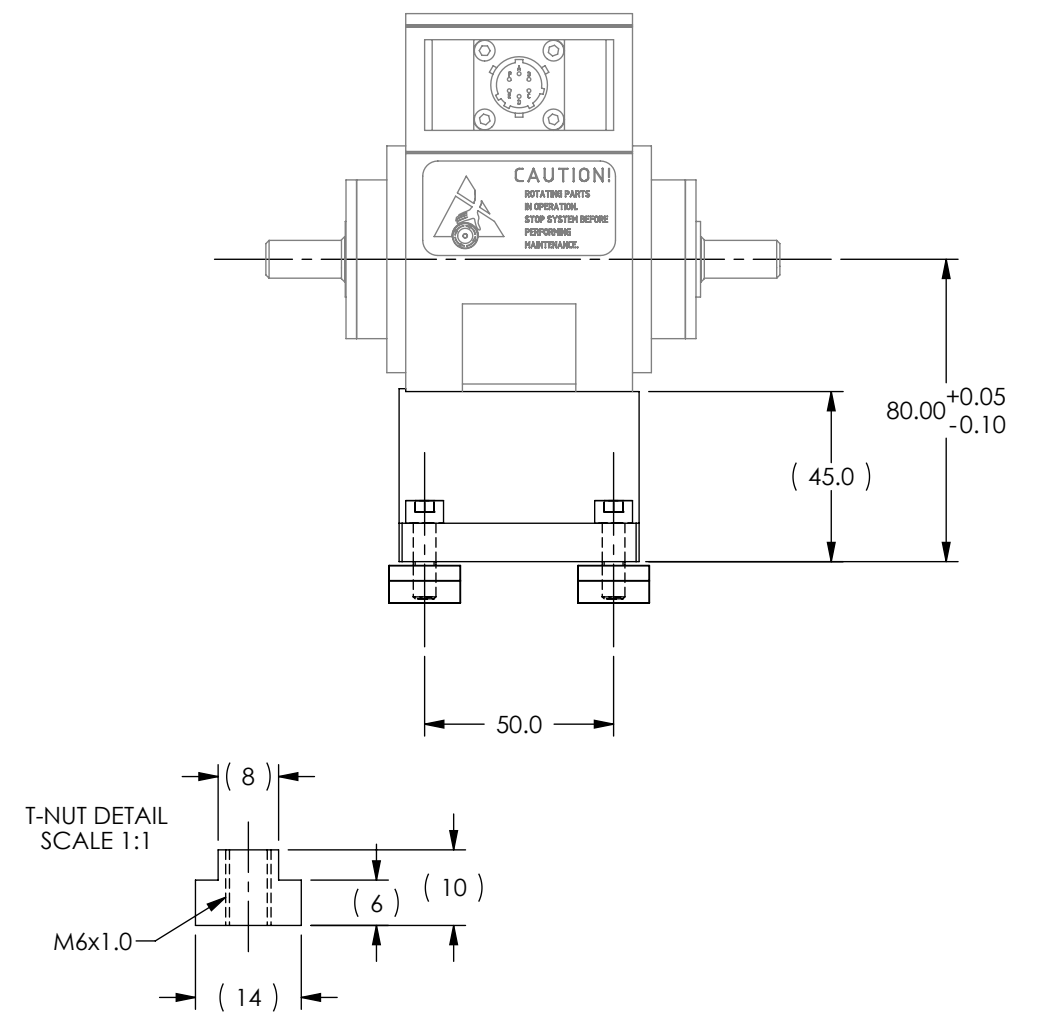
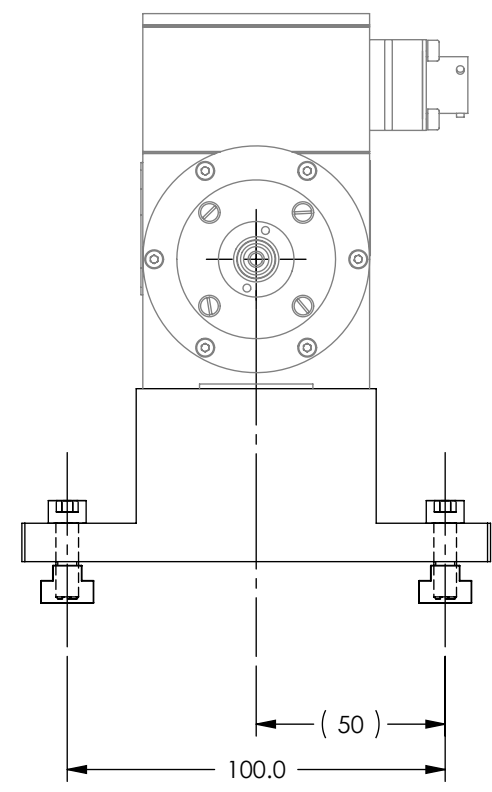
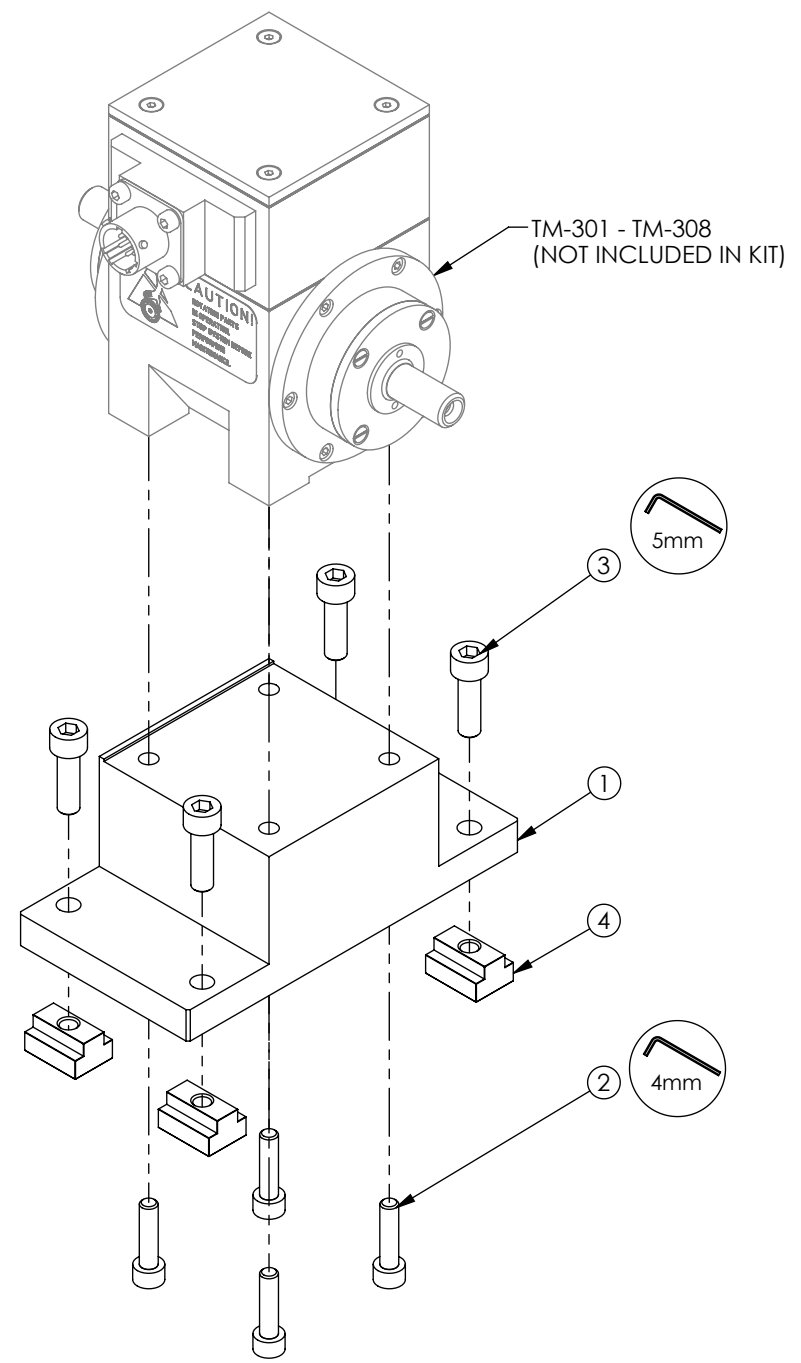

STOCK CODE: 005795  
RISER KIT DESIGNED FOR AHB-3 OR AHB-6 AND PT SERIES, T-SLOT BASE PLATES

MATERIAL:	DESIGN	JEF	08/07/06	 <b>MAGTROL INC.</b> 70 GARDENVILLE PKWY, W. BUFFALO, NEW YORK 14224-1322
	DRAWN	JEF	06/06/08	
FINISH:	CHECKED	DTW	06/06/08	TITLE
THIRD ANGLE PROJECTION	UNLESS OTHERWISE SPECIFIED: DIMENSIONS ARE IN MILLIMETERS, DIAMETERS CONCENTRIC: .08 TIR, FACES PERPENDICULAR: .08 INTERPRETATION PER ASME Y14.5M-1994 REMOVE ALL BURRS AND BREAK SHARP EDGES .13/.25 X 45°, ALL INSIDE CORNERS TO BE .5 R MAX. TOLERANCES: X ± .4            .XX ± .13 .X ± .25        ANG. ± 1° SURFACE FINISH 3.2 μm MAX. U.O.S.			RTM-1-080 RISER KIT
THIS DRAWING AND SPECIFICATION CONTAINS PROPRIETARY INFORMATION TO MAGTROL INC. ANY DISCLOSURE OR REPRODUCTION OF THIS DOCUMENT WITHOUT WRITTEN AUTHORIZATION FROM MAGTROL INC. IS EXPRESSLY PROHIBITED				USED ON: - SIMILAR TO: - DWG. NO.
				RTM-1-080
	SIZE	SCALE	SHEET #	REV
	B	1:2	2 OF 2	-