

3 DIMENSIONAL VIEW
SCALE 1 : 12

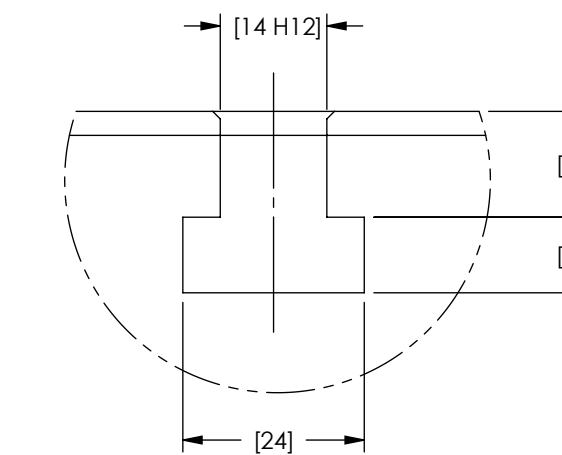
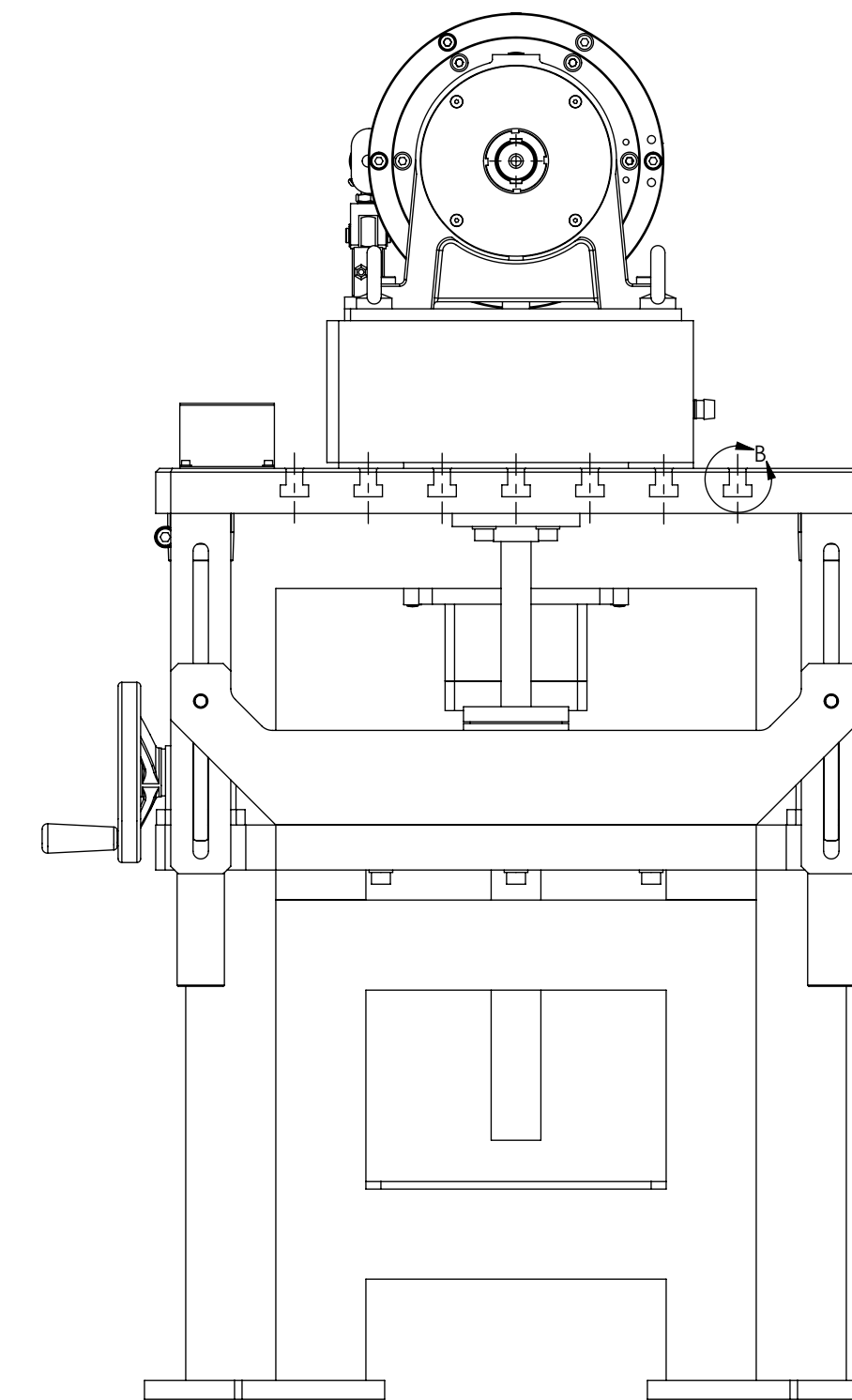
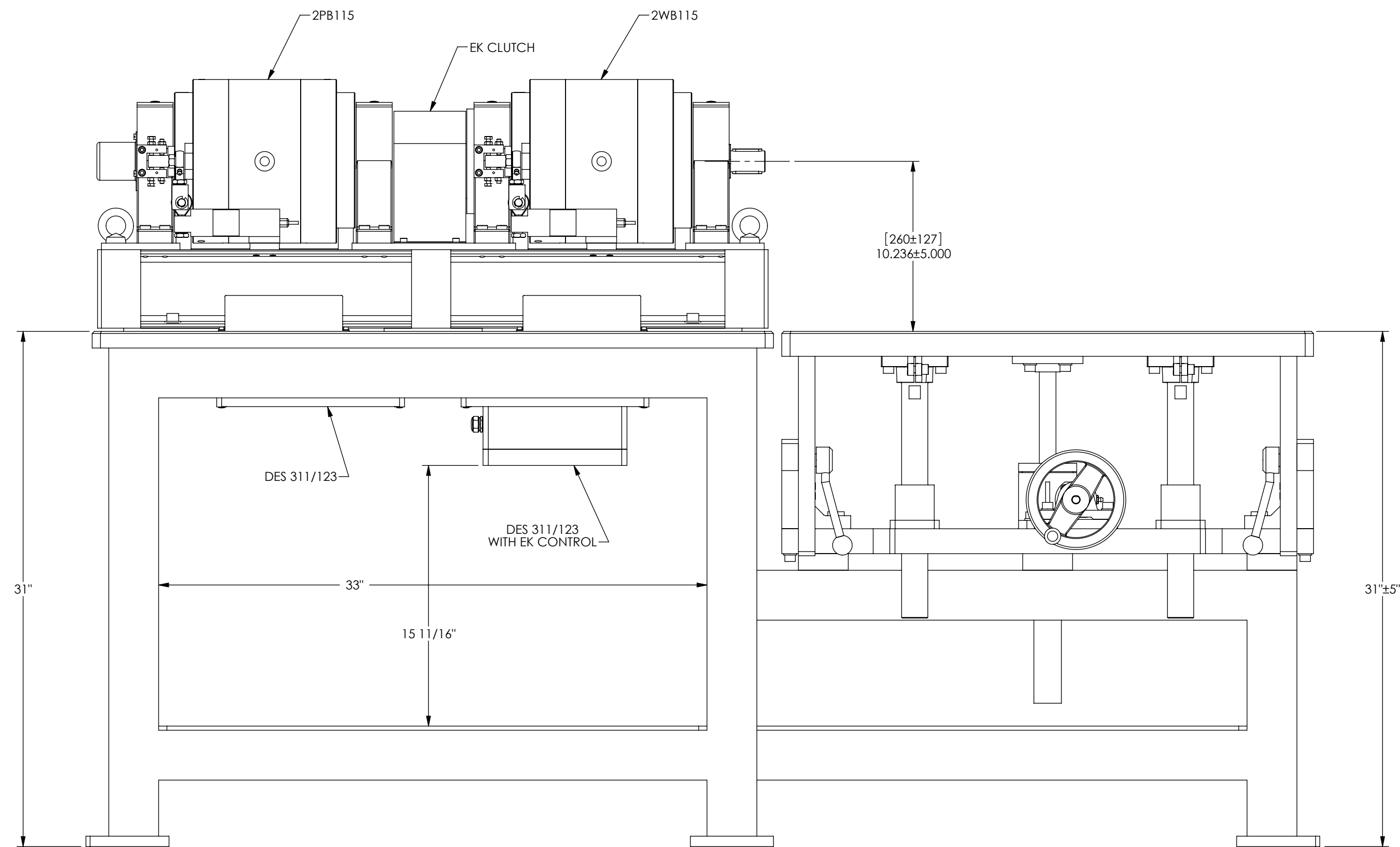

DETAIL B
SCALE 1 : 1
7X M14 H12 T-SLOT

NOTE:
DIMENSIONS IN [] ARE MILLIMETERS

MATERIAL	DESIGN	DTW	11-16-07	<p>MAGTROL INC. 70 GARDENVILLE PKWY, W. BUFFALO, NEW YORK 14224-1322</p>
FINISH	DRAWN	DTW	11-27-07	
	CHECKED	-	-	
THIRD ANGLE PROJECTION	UNLESS OTHERWISE SPECIFIED: DIMENSIONS ARE IN INCHES. DIAMETERS CONCENTRIC-.003 TIR. FACES PERPENDICULAR-.003 INTERPRETATION PER ASME Y14.5M-1994 REMOVE ALL BURRS AND BREAK SHARP EDGES .005/.010 X 45°. ALL INSIDE CORNERS TO BE .02 R MAX. TOLERANCES: .XX ±.01 FRAC. ±1/64" .XXX ±.005 ANG. ±1° SURFACE FINISH 125 RMS MAX. U.O.S.			TITLE TAB 0115 TL 2WB115 TANDEM LIFT
THIS DRAWING AND SPECIFICATION CONTAINS PROPRIETARY INFORMATION TO MAGTROL INC. ANY DISCLOSURE OR REPRODUCTION OF THIS DOCUMENT WITHOUT WRITTEN AUTHORIZATION FROM MAGTROL INC. IS EXPRESSLY PROHIBITED				SHEET NO. 204127 DWG. NO. S10225 SIZE D SCALE 1:6 SHEET # 1 OF 1

LETTER	DATE	BY	ECN	DESCRIPTION
REVISIONS				