

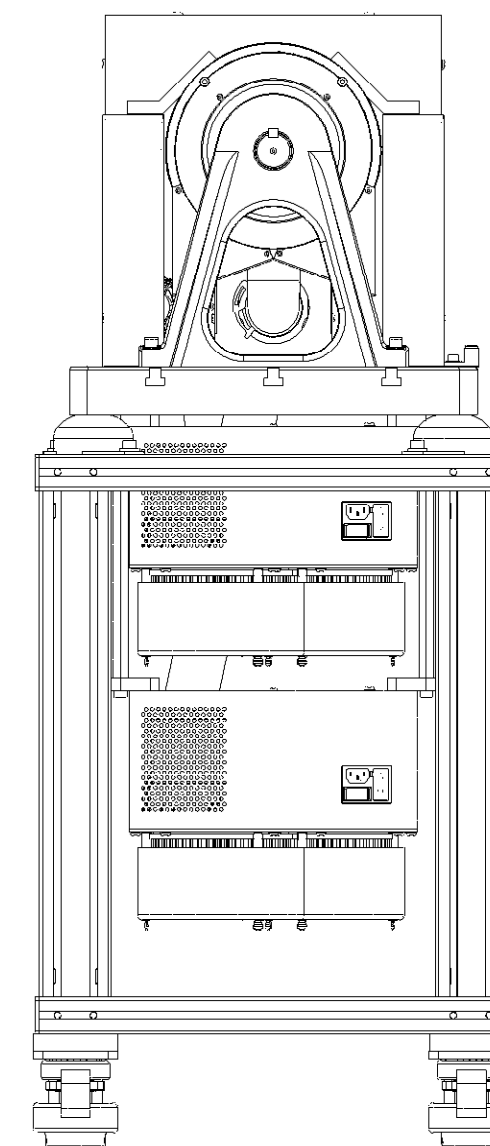

SOLID MODEL AVAILABLE

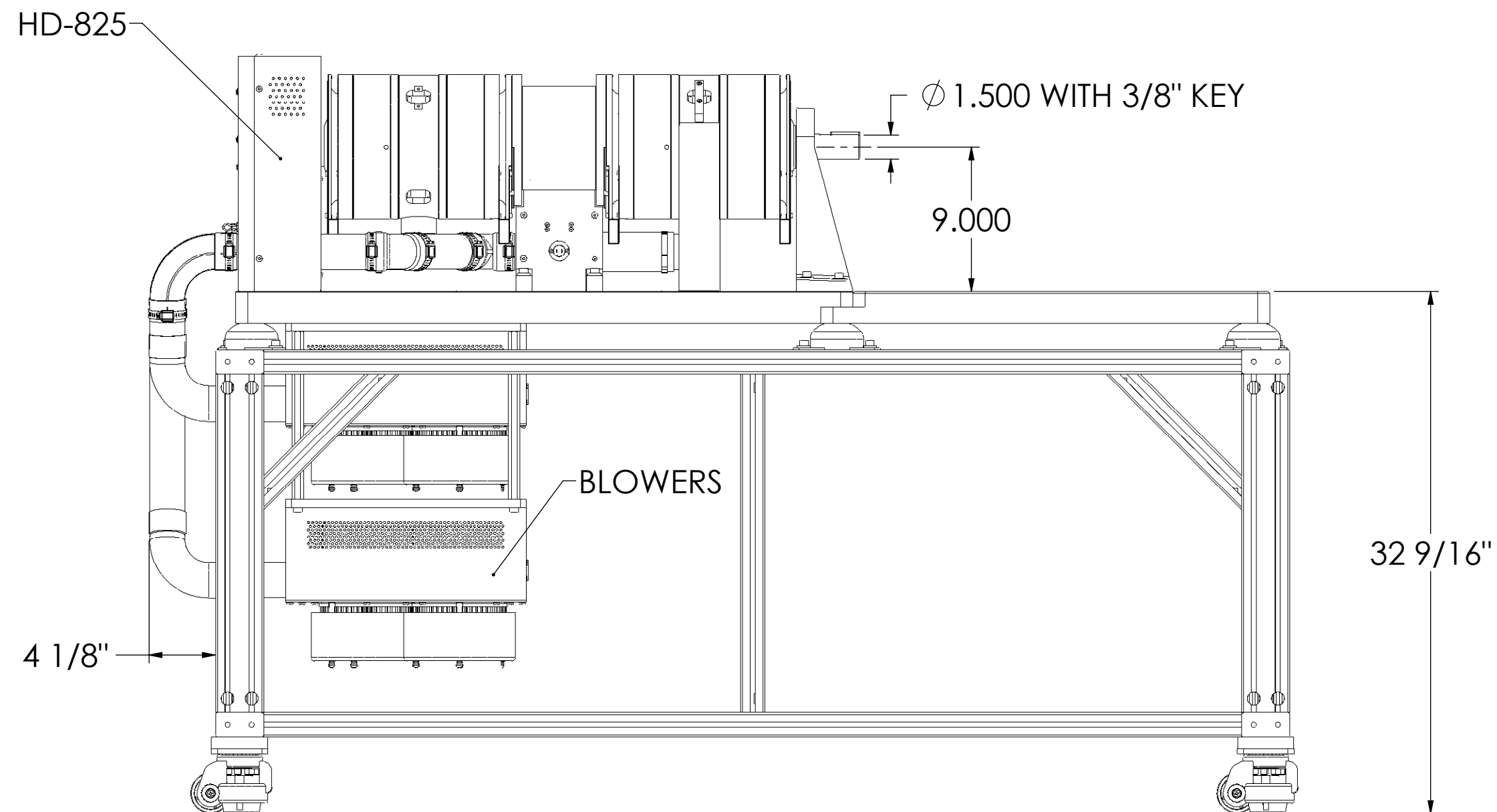
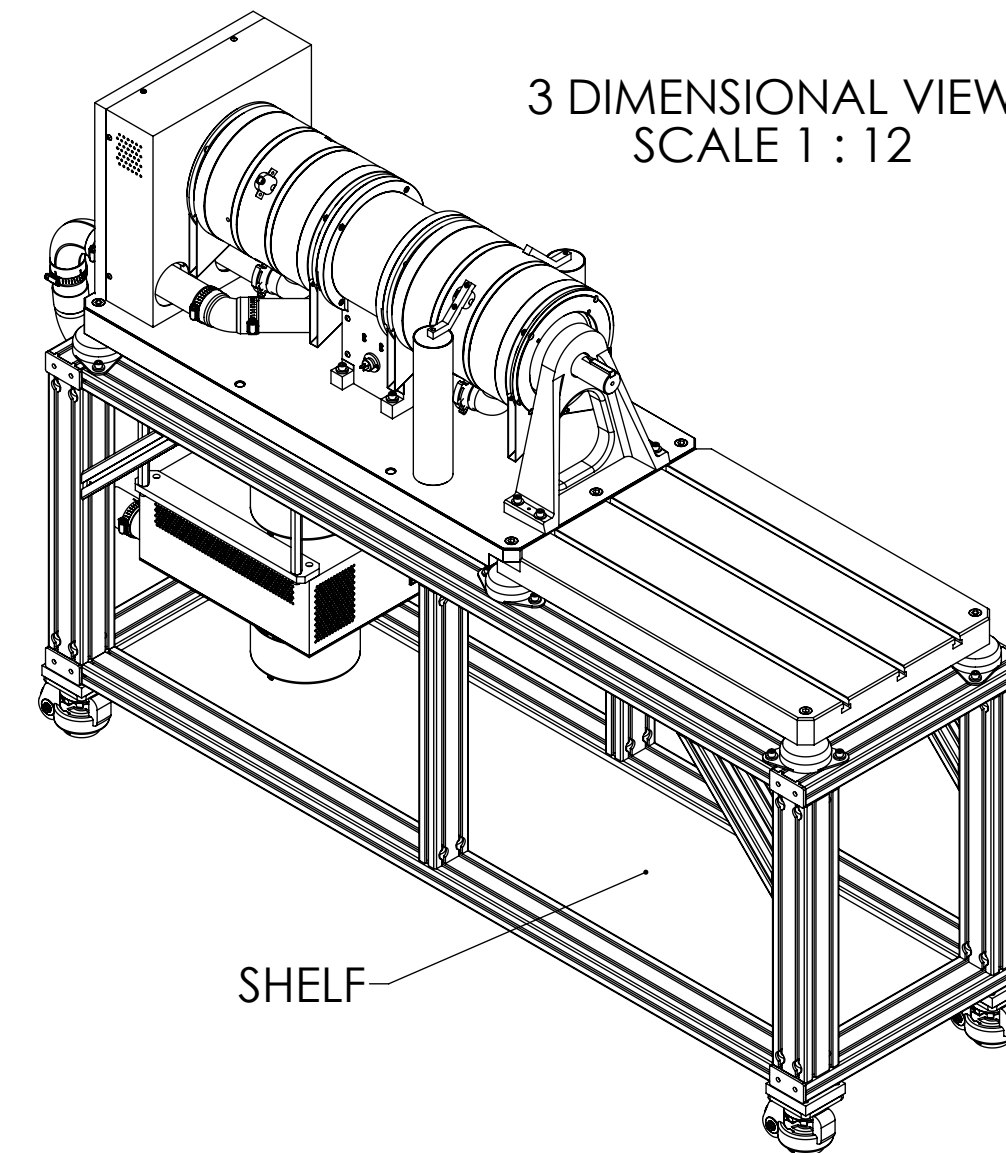
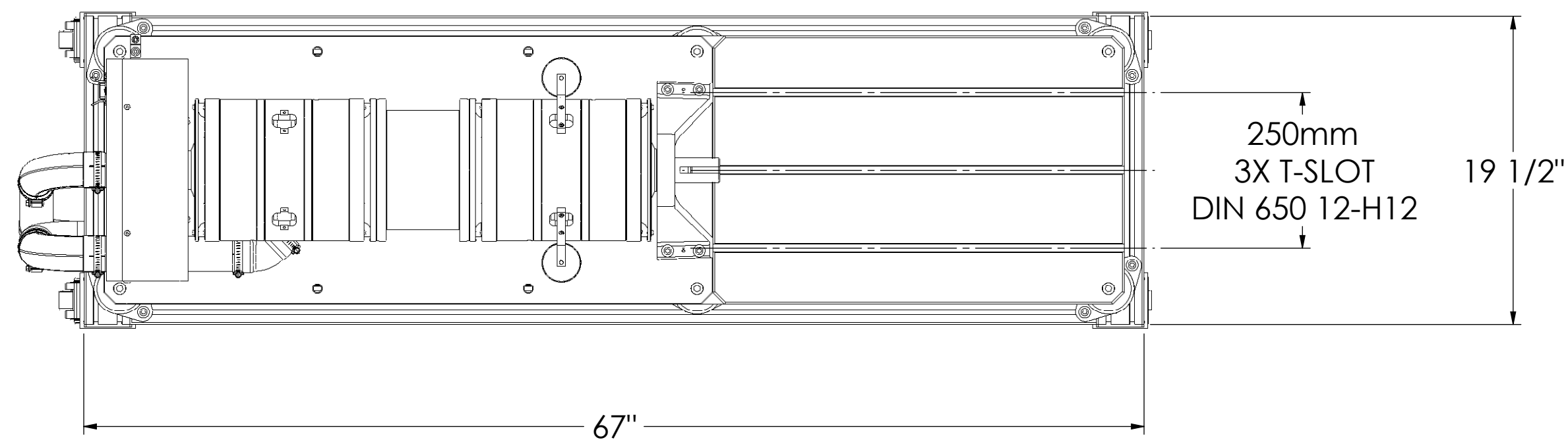
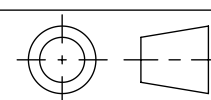

MATERIAL:	DESIGN	DTW	12-20-04	 <b>MAGTROL INC.</b> 70 GARDENVILLE PKWY, W. BUFFALO, NEW YORK 14224-1322				
FINISH:	DRAWN	DTW	01-20-06					
	CHECKED							
THIRD ANGLE PROJECTION				TITLE				
THIS DRAWING AND SPECIFICATION CONTAINS PROPRIETARY INFORMATION TO MAGTROL INC. ANY DISCLOSURE OR REPRODUCTION OF THIS DOCUMENT WITHOUT WRITTEN AUTHORIZATION FROM MAGTROL INC. IS EXPRESSLY PROHIBITED	UNLESS OTHERWISE SPECIFIED: DIMENSIONS ARE IN INCHES, DIAMETERS CONCENTRIC-.003 TIR, FACES PERPENDICULAR-.003 INTERPRETATION PER ASME Y14.SM-1994 REMOVE ALL BURRS AND BREAK SHARP EDGES .005/.010 X 45°. ALL INSIDE CORNERS TO BE .02 R MAX. TOLERANCES			TAB 0825L WITH HD-825				
	.XX $\pm .01$ FRAC. $\pm 1/64$ " .XXX $\pm .005$ ANG. $\pm 1^\circ$ SURFACE FINISH 125 RMS MAX. U.O.S.			USED ON: DWG. NO. <b>005479</b>				
	REVISIONS	SIZE	SCALE	SHEET #	REV			
LETTER	DATE	BY	ECN	DESCRIPTION	C	1:8	1 OF 1	-