

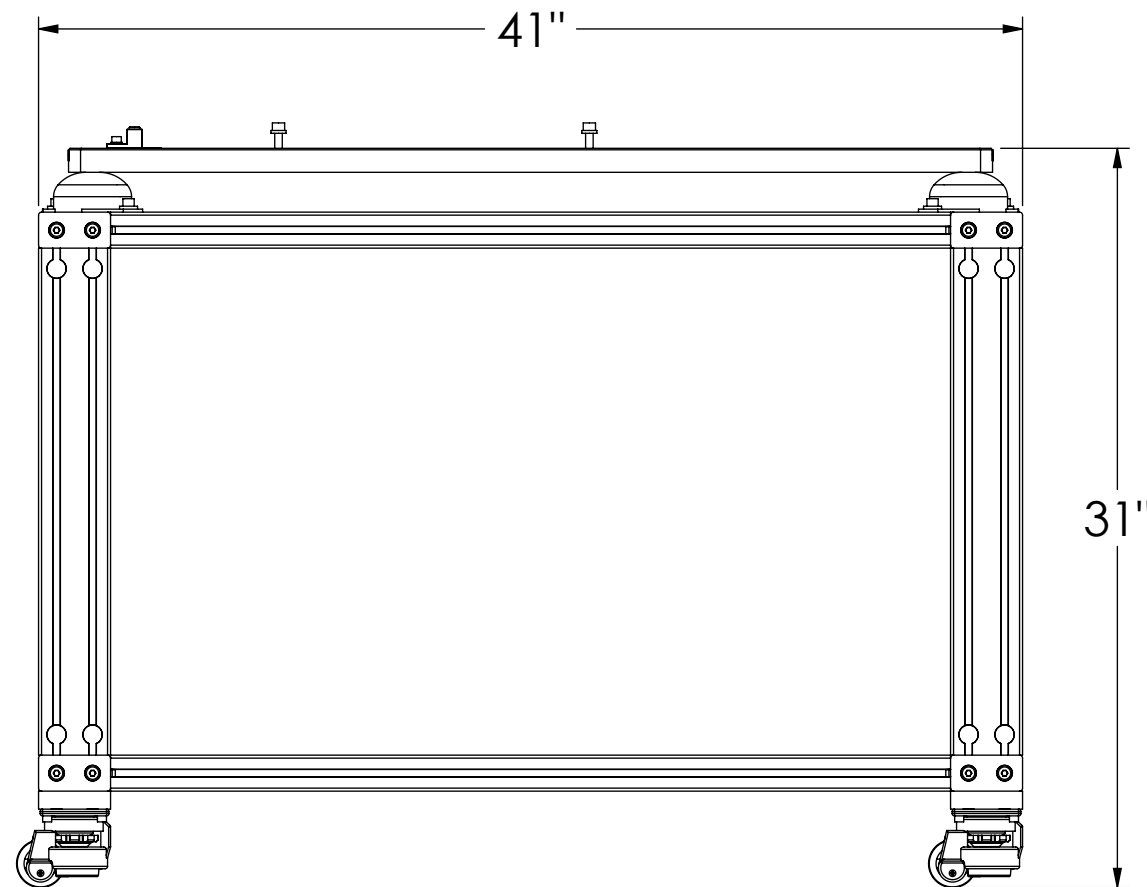

SOLID MODEL AVAILABLE

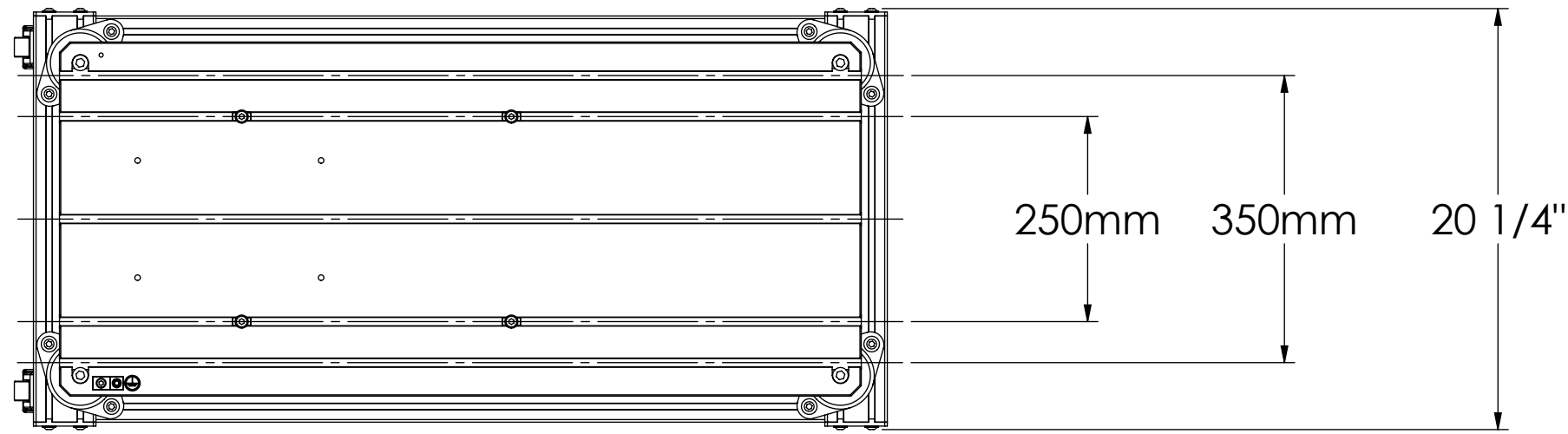

5X T-SLOT
DIN 650 8-H12

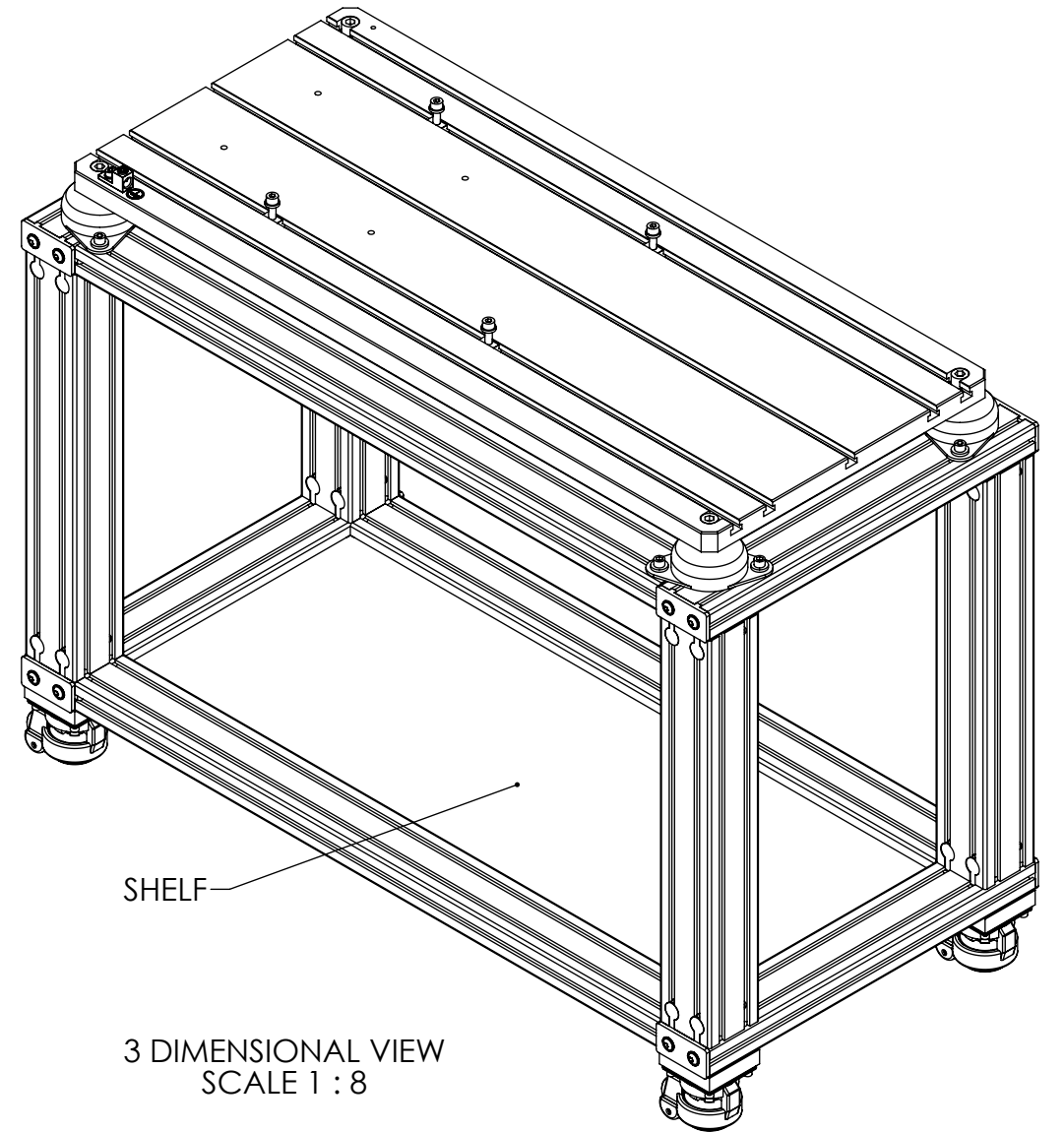
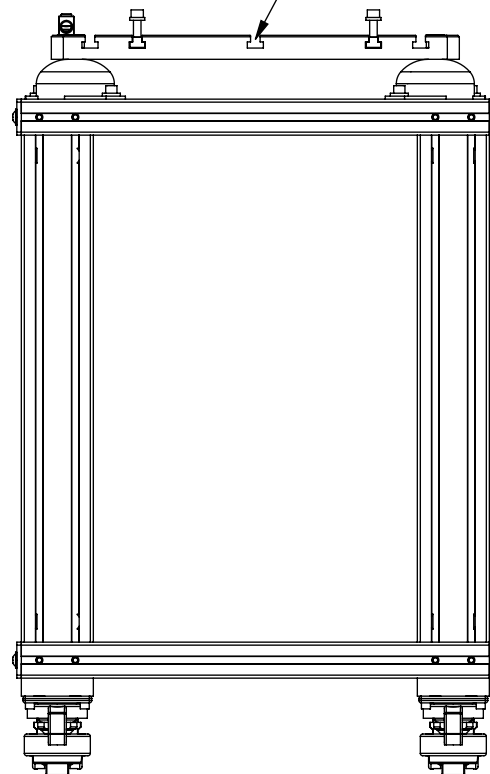

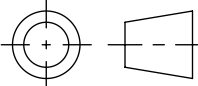
MATERIAL:	DESIGN	DTW	12/06/04	 MAGTROL INC. 70 GARDENVILLE PKWY, W. BUFFALO, NEW YORK 14224-1322
-	DRAWN	JEF	03/30/05	
FINISH:	CHECKED	-	-	TITLE
-				TAB 1457S HD-106/715-0100'S
THIRD ANGLE PROJECTION				USED ON: - SIMILAR TO: -
THIS DRAWING AND SPECIFICATION CONTAINS PROPRIETARY INFORMATION TO MAGTROL INC. ANY DISCLOSURE OR REPRODUCTION OF THIS DOCUMENT WITHOUT WRITTEN AUTHORIZATION FROM MAGTROL INC. IS EXPRESSLY PROHIBITED	UNLESS OTHERWISE SPECIFIED: DIMENSIONS ARE IN INCHES, DIAMETERS CONCENTRIC-.003 TIR, FACES PERPENDICULAR-.003 INTERPRETATION PER ASME Y14.5M-1994 REMOVE ALL BURRS AND BREAK SHARP EDGES .005/.010 X 45°, ALL INSIDE CORNERS TO BE .02 R MAX. TOLERANCES .XX ±.01 FRAC.±1/64" .XXX ±.005 ANG. ±1° SURFACE FINISH 125 RMS MAX. U.O.S.			DWG. NO.
				005032
	SIZE	SCALE	SHEET #	REV
B	1:8	2 OF 2	-	