

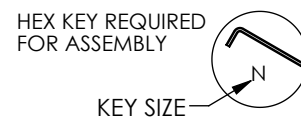

ITEM NO.	PART NUMBER	DESCRIPTION	QTY.
1	204352	RISER BLOCK, RTM-2-120	1
2	504215	T-NUT, M6x1.0 X 8mm SLOT WIDTH	4
3	505677	SHCS M6x1 X 20mm 18-8 SS	8

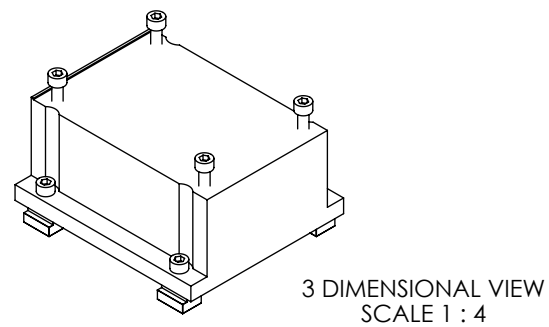
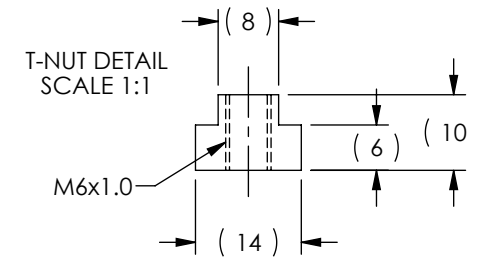
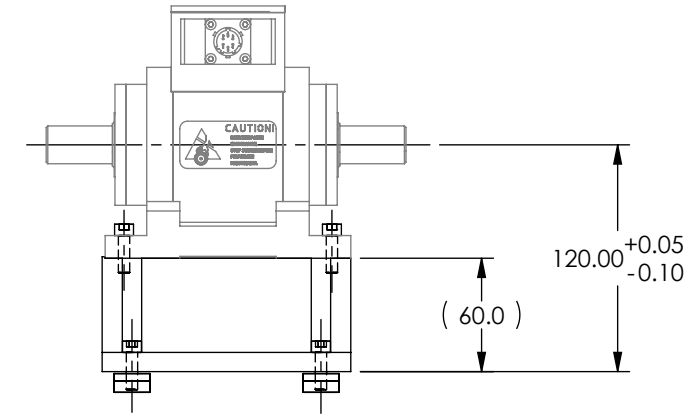
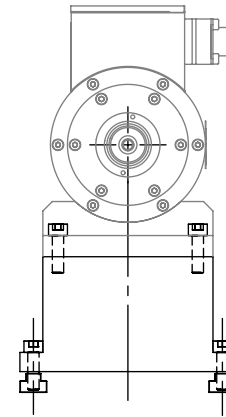
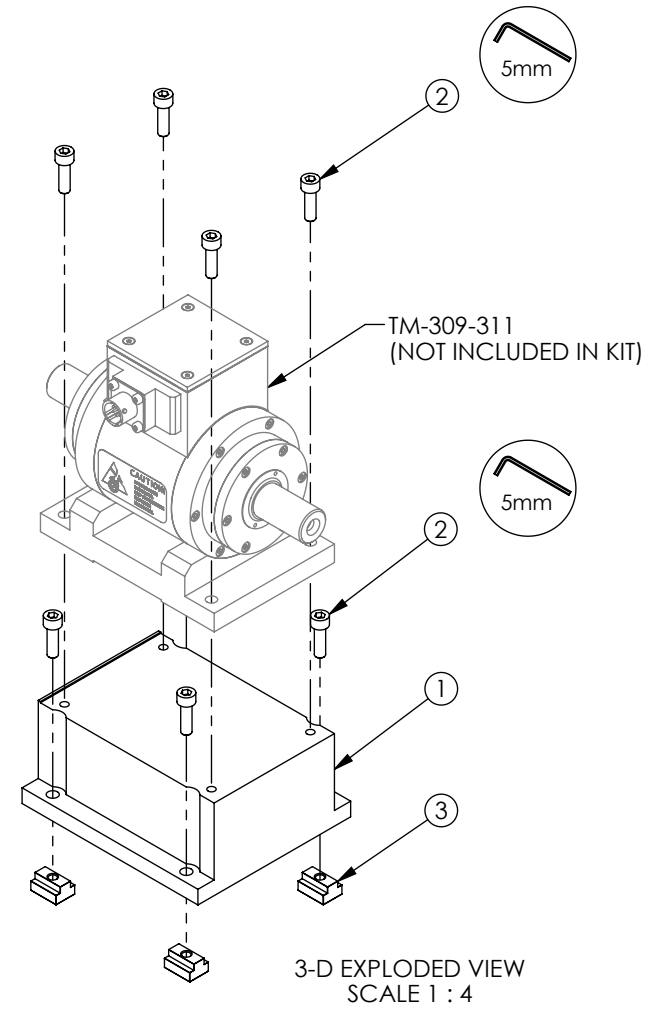
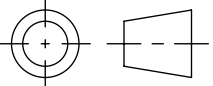

STOCK CODE: 005674
RISER KIT DESIGNED FOR AHB-24 AND PT SERIES, T-SLOT BASE PLATES

MATERIAL:	DESIGN	JEF	01/13/06	 MAGTROL INC. 70 GARDENVILLE PKWY, W. BUFFALO, NEW YORK 14224-1322	TITLE RTM-2-120 RISER KIT	
	DRAWN	JEF	01/16/06			
FINISH:	CHECKED	DTW	01/20/06			
THIRD ANGLE PROJECTION				UNLESS OTHERWISE SPECIFIED: DIMENSIONS ARE IN MILLIMETERS, DIAMETERS CONCENTRIC: .08 TIR, FACES PERPENDICULAR: .08 INTERPRETATION PER ASME Y14.5M-1994 REMOVE ALL BURRS AND BREAK SHARP EDGES .13/.25 X 45°, ALL INSIDE CORNERS TO BE .5 R MAX. TOLERANCES: X ± .4 .XX ± .13 .X ± .25 ANG. ± 1° SURFACE FINISH 3.2 μm MAX. U.O.S.	USED ON: - SIMILAR TO: - DWG. NO. RTM-2-120	REV A
THIS DRAWING AND SPECIFICATION CONTAINS PROPRIETARY INFORMATION TO MAGTROL INC. ANY DISCLOSURE OR REPRODUCTION OF THIS DOCUMENT WITHOUT WRITTEN AUTHORIZATION FROM MAGTROL INC. IS EXPRESSLY PROHIBITED	SIZE	SCALE	SHEET #			
	B	1:4	2 OF 2			